

TOP 15 ADVANTAGES

1. **Optional stoker opening** to convert from wood to coal and biomass burning.
2. **Self venting expansion stack.**
3. **R20 fiberglass** is used on walls and roof. Styrofoam is used on the bottom.
4. **Extra large insulated door** with gasket seal. Door is adjustable to maintain controlled burn.
5. **Adjustable aquastat and natural draft damper.** Natural draft is more efficient than forced air draft.
6. **Low water cut-off and water level sight gauge.**
7. **Heat exchange water tubes**, through the firebox, increases heat transferring surface area and efficiency.
8. **Cast iron grates** ensures longer life and lets you remove ashes without extinguishing fire.
9. **High efficiency water jacket** ensures fast recovery.
10. **7 gauge steel firebox ensures long life.** Large chamber easily takes 4' long logs or square bales. Big capacity keeps refueling down to a minimum.
11. **Returning cooled water is uniformly distributed** along the top of the water jacket.
12. **Insulated stainless steel chimney** is standard. Hinged baffle at chimney re-directs exhaust gases for a secondary burn.
13. **Lifting ring.**
14. **Pull out ash pan** on all models. **Separate ash pan door** on models V-92 and VI-92.
15. **Double latch door system.**

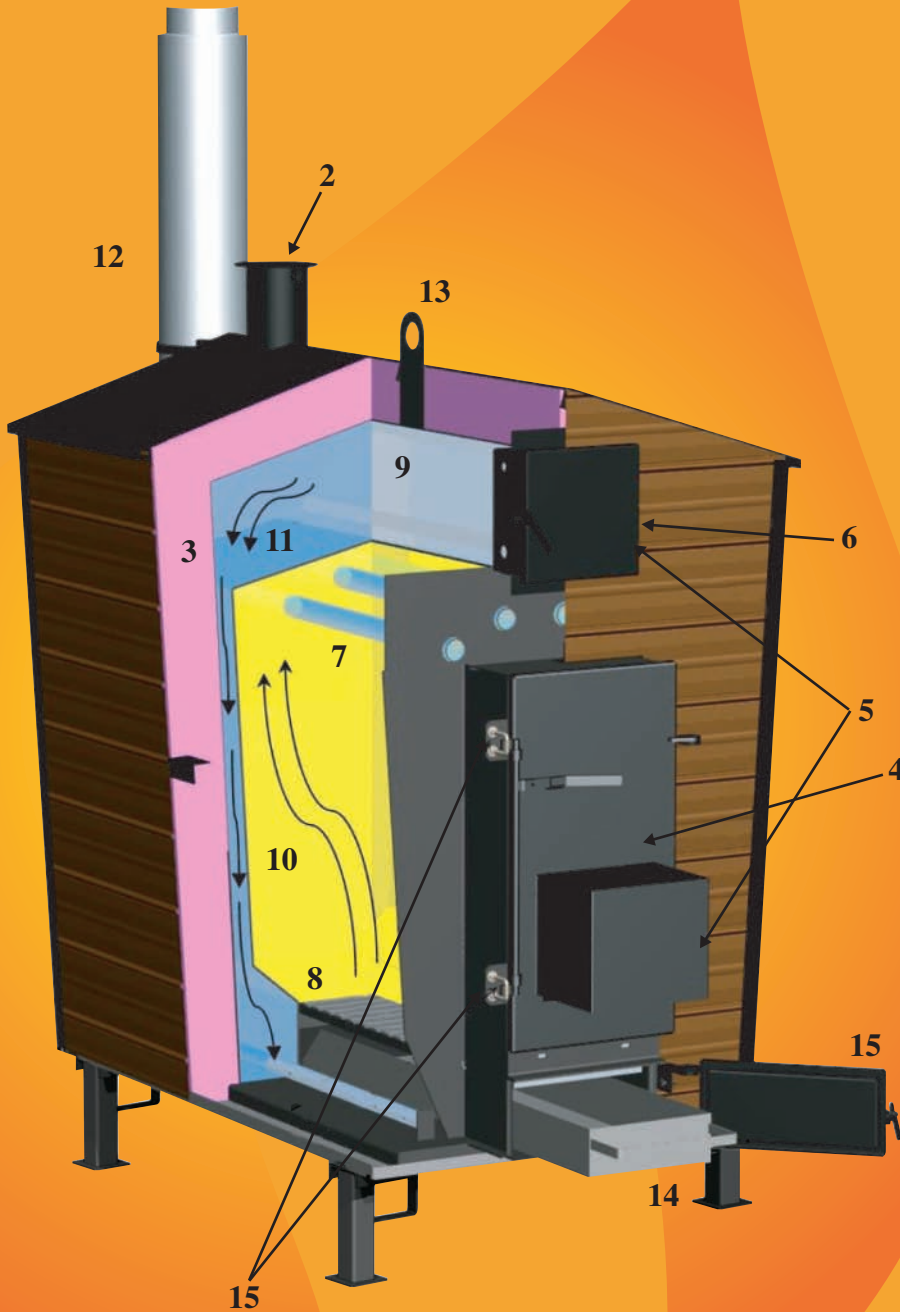

HEAT 
INNOVATIONS

Box 989, 499 Manitoba Road
Winkler, Manitoba, Canada R6W 4B1
Toll Free: (888) 385-HEAT (4328)
Phone: (204) 325-4253
Fax: (204) 325-0628
www.heatinnovations.com

	Homesteader IV	Homesteader V	Homesteader VI
7 ga. Steel	Yes	Yes	Yes
Legs	Yes	Yes	Yes
Total Width	45"	55"	67"
Total Height	89"	100"	108"
Total Length	70 1/2"	70 1/2"	70 1/2"
Chimney Size	8"	8"	8"
Door Size	18"x 36"	18"x 36"	18"x 36"
Fire Box Size	3'x3'x5'	4'x3'x5'	5'x4'x5'
Water Capacity - Imperial	200 gal.	230 gal.	330 gal.
(U.S. gal.)	(240 U.S. Gal)	(276 U.S. Gal)	(396 U.S. Gal)
Approximate Heating Area	250,000 BTU/HR 5000 sq.ft.	300,000 BTU/HR 7500 sq.ft.	600,000 BTU/HR 12,000 sq.ft.
Shipping Weight	1900 lbs.	2300 lbs.	2900 lbs.

At Heat Innovations we strive to provide top quality, reliable heating solutions that save you money.

Available through your authorized
Homesteader / Coalman dealer

Manufactured By:
Heat Innovations Inc.
Winkler, MB.
204.325.4253
1.888.385.4328
www.heatinnovations.com

